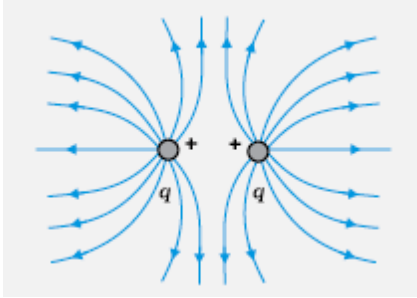
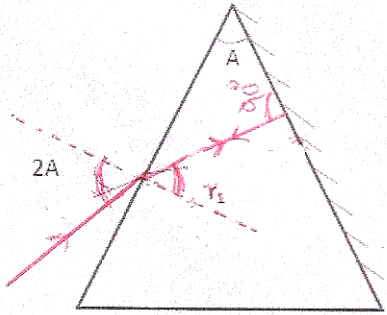

MARKING SCHEME

SET 55/1/MT

Q. No.	Expected Answer / Value Points	Marks	Total Marks				
Section A							
Set1,Q1 Set2,Q5 Set3,Q4	 <p>[Award ½ mark if the student just writes that the field lines radiate outwards from a positive charge]</p>	1	1				
Set1,Q2 Set2,Q4 Set3,Q5	Convex lens OR Converging lens	1	1				
Set1,Q3 Set2,Q2 Set3,Q1	<p>A current is said to be wattless if the average power consumed over one complete cycle is zero.</p> <p>Alternatively, In a a.c. circuit containing pure inductor or pure capacitor the phase difference between voltage and current is $\pi/2$. Hence $\cos \phi = 0$ and no power is dissipated even though a current is flowing in the circuit. This current is referred as wattless current.</p> <p>Alternatively, The component of the current perpendicular to the applied voltage ($I_v \sin \phi$) does not contribute power in an LCR circuit. Hence it is referred as wattless current.</p>	1	1				
Set1,Q4 Set2,Q3 Set3,Q2	Repeaters are used to increase/extend the range of a communication system.	1	1				
Set1,Q5 Set2,Q1 Set3,Q3	B has higher resistivity. Alternatively, B	1	1				
Section B							
Set1,Q6 Set2,Q8 Set3,Q9	<table border="1" data-bbox="260 1608 1249 1720"> <tr> <td>Formula</td> <td align="right">½</td> </tr> <tr> <td>Ratio of the de-Broglie wavelengths</td> <td align="right">1 ½</td> </tr> </table> <p>De-Broglie wavelength $\lambda = \frac{h}{\sqrt{2mqV}}$</p> <p>Ratio of de-Broglie wavelengths of deuterons and α - particle</p> $= \frac{\lambda_D}{\lambda_\alpha} = \frac{\sqrt{2m_\alpha q_\alpha V}}{\sqrt{2m_d q_d V}}$ $= \frac{\sqrt{2 \times 4m_p \times 2qV}}{\sqrt{2 \times 2m_p \times q \times V}}$ $= 2$	Formula	½	Ratio of the de-Broglie wavelengths	1 ½	½ ½ ½ ½	2
Formula	½						
Ratio of the de-Broglie wavelengths	1 ½						

<p>Set1,Q7 Set2,Q9 Set3,Q10</p>	<table border="1" style="width: 100%;"> <tr> <td style="width: 60%;">Identifying the transitions</td> <td style="width: 40%; text-align: right;">1/2 + 1/2</td> </tr> <tr> <td>Calculating the ratio of shortest wavelengths</td> <td style="text-align: right;">1</td> </tr> </table> <p>Lyman series - C and E Blamer Series – B and D</p> <p>Ratio of the shortest wavelength $\frac{\lambda_L}{\lambda_B} = \frac{3}{10} = 0.3$</p> <p>Alternatively</p> <p>Ratio of the shortest wavelength $\frac{\lambda_L}{\lambda_B} = \frac{n_1^2}{n_2^2} = \frac{1}{4}$</p> <p>[<u>Note</u>: The student may write that Lyman and Balmer series are defined for the hydrogen atom and the given energy level values do not correspond to hydrogen. Hence one cannot identify the Lyman and Balmer series in the given case. Full credit may be given for this type of answer]</p>	Identifying the transitions	1/2 + 1/2	Calculating the ratio of shortest wavelengths	1	<p>1/2 1/2 1</p>	2		
Identifying the transitions	1/2 + 1/2								
Calculating the ratio of shortest wavelengths	1								
<p>Set1,Q8 Set2,Q10 Set3,Q7</p>	<table border="1" style="width: 100%;"> <tr> <td style="width: 60%;">Determining the value of modulation Index</td> <td style="width: 40%; text-align: right;">1</td> </tr> <tr> <td>Value of μ when amplitude is zero</td> <td style="text-align: right;">1/2</td> </tr> <tr> <td>Reason for $\mu < 1$</td> <td style="text-align: right;">1/2</td> </tr> </table> $A_c + A_m = 10 V$ $A_c - A_m = 2 V$ <p>On solving we get Modulation Index $\mu = \frac{A_m}{A_c} = \frac{4}{6} = \frac{2}{3}$</p> <p>If the value of minimum amplitude $A_c - A_m = 0, A_c = A_m = 5V$</p> <p>Then $\mu = \frac{A_m}{A_c} = 1$</p> <p>$\mu$ is kept less than one to avoid distortion.</p>	Determining the value of modulation Index	1	Value of μ when amplitude is zero	1/2	Reason for $\mu < 1$	1/2	<p>1/2 1/2 1/2 1/2</p>	2
Determining the value of modulation Index	1								
Value of μ when amplitude is zero	1/2								
Reason for $\mu < 1$	1/2								
<p>Set1,Q9 Set2,Q6 Set3,Q8</p>	<table border="1" style="width: 100%;"> <tr> <td style="width: 60%;">Diagram</td> <td style="width: 40%; text-align: right;">1</td> </tr> <tr> <td>Relation between refractive index and angle of the prism</td> <td style="text-align: right;">1</td> </tr> </table> <div style="text-align: center;">  <p>$A = r_1 + r_2$ (Here $r_2 = 0$)</p> </div>	Diagram	1	Relation between refractive index and angle of the prism	1	1			
Diagram	1								
Relation between refractive index and angle of the prism	1								

$$A = r_1$$

$$\text{Refractive index of the material is } \mu = \frac{\sin i}{\sin r} = \frac{\sin 2A}{\sin A} \\ (= 2 \cos A)$$

1/2

1/2

OR

2

Image for the first lens

1/2

Formula for the second lens and substituting correct values

1/2

Calculating the distance between initial and final positions of the image

1

For convex lens

$$u = -40 \text{ cm}, f = +30 \text{ cm}$$

$$\therefore \frac{1}{30} = \frac{1}{v} - \frac{1}{-40}$$

1/2

$$\therefore v = 120 \text{ cm}$$

On introducing concave lens of focal length $f = -50 \text{ cm}$

$$f = -50 \text{ cm}, u = +(120-20) \text{ cm} = +100 \text{ cm}$$

1/2

$$\therefore \frac{1}{-50} = \frac{1}{v} - \frac{1}{100}$$

$$\therefore \frac{1}{v} = \frac{1}{100} - \frac{1}{50} = -\frac{1}{100}$$

1/2

$$\therefore v = -100 \text{ cm}$$

Change in the position of the image = 200 cm to the left of its original position.

1/2

2

Set1,Q10
Set2,Q7
Set3,Q6

Calculation of potential gradient

1

Calculation of unknown resistance R

1

$$\text{Current through the wire } I = \frac{E}{\frac{R+r}{2}} \\ = \frac{E}{R+15}$$

1/2

$$\therefore \text{Potential gradient} = \left(\frac{2}{R+15} \right) \times \frac{15}{100}$$

1/2

Now $E_2 =$ Potential drop across 30 cm

$$\therefore 75 \times 10^{-3} = \left(\frac{2}{R+15} \right) \times 0.15 \times 30$$

1/2

$$\therefore R = 105 \Omega$$

1/2

2

Section C

Set1,Q11 Set2,Q20 Set3,Q17	<table style="width: 100%; border-collapse: collapse;"> <tr> <td style="padding: 2px;">Formulae</td> <td style="text-align: right; padding: 2px;">1</td> </tr> <tr> <td style="padding: 2px;">Calculating energy loss</td> <td style="text-align: right; padding: 2px;">1 ½</td> </tr> <tr> <td style="padding: 2px;">Source of energy loss</td> <td style="text-align: right; padding: 2px;">½</td> </tr> </table> <p style="margin-top: 10px;">We have, energy stored = $\frac{1}{2} \frac{Q}{C}$ and Equivalent Capacitance = $C_1 + C_2$ $= (600 + 300) \text{ pF}$</p> <p>Charge on the capacitor = $Q = 600 \times 200 \times 10^{-12}$ $= 12 \times 10^{-8} \text{ C}$</p> <p>Initial Energy = $\frac{1}{2} \frac{Q^2}{C} = \frac{1}{2} \frac{Q^2}{600 \times 10^{-12}}$</p> <p>Final Energy = $\frac{1}{2} \frac{Q^2}{900 \times 10^{-12}}$</p> <p>Loss in energy = $\frac{1}{2} \frac{144 \times 10^{-16}}{10^{-12}} \left[\frac{1}{600} - \frac{1}{900} \right]$ $= 4 \times 10^{-6} \text{ J}$</p> <p>The source of energy loss is the energy converted into heat due to sharing of charge between the two capacitors. (Also accept: heat produced) [Alternatively: Also accept if the student calculates directly.]</p>	Formulae	1	Calculating energy loss	1 ½	Source of energy loss	½	½ ½ ½ ½ ½ ½	3				
Formulae	1												
Calculating energy loss	1 ½												
Source of energy loss	½												
Set1,Q12 Set2,Q21 Set3,Q18	<table style="width: 100%; border-collapse: collapse;"> <tr> <td style="padding: 2px;">Production of i) microwaves</td> <td style="text-align: right; padding: 2px;">½</td> </tr> <tr> <td style="padding: 2px;">ii) infrared waves</td> <td style="text-align: right; padding: 2px;">½</td> </tr> <tr> <td style="padding: 2px;">Two uses of each wave</td> <td style="text-align: right; padding: 2px;">$(\frac{1}{2} + \frac{1}{2}) \times 2$</td> </tr> </table> <p style="margin-top: 10px;">i) Microwaves are produced by special vacuum tubes called Klystrons / Magnetrons / Gun diodes / Point contact diodes. (<u>any one</u>) Uses: Radar system, Ovens, Communication (<u>any two</u>)</p> <p>ii) Infrared waves are produced by vibration of atoms and hot bodies. Uses: Physical therapy, remote switches in household electronic systems, detectors in earth satellites (<u>any two</u>)</p>	Production of i) microwaves	½	ii) infrared waves	½	Two uses of each wave	$(\frac{1}{2} + \frac{1}{2}) \times 2$	½ ½ + ½ ½ ½ + ½	3				
Production of i) microwaves	½												
ii) infrared waves	½												
Two uses of each wave	$(\frac{1}{2} + \frac{1}{2}) \times 2$												
Set1,Q13 Set2,Q22 Set3,Q19	<table style="width: 100%; border-collapse: collapse;"> <tr> <td style="padding: 2px;">Drawing circuit diagrams of a p - n junction diode in</td> <td></td> </tr> <tr> <td style="padding: 2px;">i) forward bias</td> <td style="text-align: right; padding: 2px;">½</td> </tr> <tr> <td style="padding: 2px;">ii) reverse bias</td> <td style="text-align: right; padding: 2px;">½</td> </tr> <tr> <td style="padding: 2px;">Drawing the characteristic curves</td> <td style="text-align: right; padding: 2px;">½ + ½</td> </tr> <tr> <td style="padding: 2px;">Describing the terms minority carrier injection and break down voltage</td> <td style="text-align: right; padding: 2px;">½ + ½</td> </tr> </table>	Drawing circuit diagrams of a p - n junction diode in		i) forward bias	½	ii) reverse bias	½	Drawing the characteristic curves	½ + ½	Describing the terms minority carrier injection and break down voltage	½ + ½	½ + ½ ½ + ½	
Drawing circuit diagrams of a p - n junction diode in													
i) forward bias	½												
ii) reverse bias	½												
Drawing the characteristic curves	½ + ½												
Describing the terms minority carrier injection and break down voltage	½ + ½												

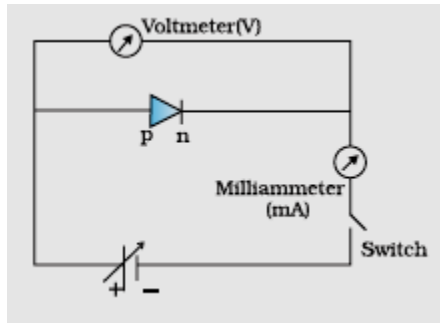

a) Forward bias

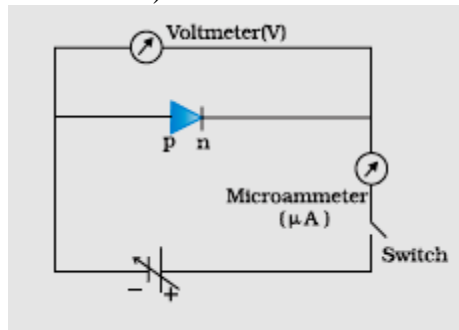

b) Reverse bias

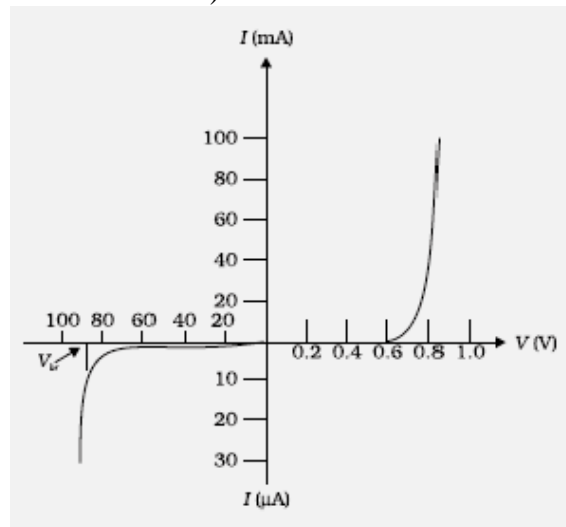

(i) During forward bias majority carriers (electrons) enter from n to p side which are actually minority carriers in p. This is called minority carrier injection.

Alternatively

Majority carriers holes enter from p side and enter into n side

(ii) At very high reverse bias voltage, the current suddenly increases. This voltage is called breakdown voltage.

Alternatively

It is the critical voltage in reverse bias at which current is independent of applied voltage.

Set1,Q14
Set2,Q11
Set3,Q20

- | | |
|---------------------------------------|---------------|
| (a) Description of elementary process | 1 |
| Equation for V_{max}^2 | 1 |
| (b) Expression for Planck's constant | $\frac{1}{2}$ |
| Expression for work function | $\frac{1}{2}$ |

(a) According to Einstein, packets of energy called photons, which are absorbed completely by electrons. This absorbed energy is used to eject the electron and also provide kinetic energy to the emitted electron.

(b) i) $\frac{1}{2} m V_{max}^2 = h\nu - \phi_0$

$$\therefore V_{max}^2 = \left(\frac{2h}{m}\right)\nu - \left(\frac{2\phi_0}{m}\right)$$

Slope = $\frac{2h}{m} = \frac{l}{n}$

$$\therefore h = \frac{m l}{2 n}$$

Intercept = $\frac{2\phi_0}{m} = l$

$$\therefore \phi_0 = \frac{m l}{2}$$

1
1/2
1/2
1/2
1/2

3

Set1,Q15
Set2,Q12
Set3,Q13

Drawing circuit diagram	1
Explanation of input / output characteristics	1
Drawing graphs showing input / output characteristics	1

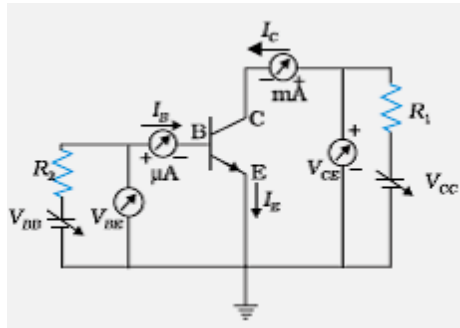

For input characteristics,
Keep V_{CE} as fixed value
Study the dependence of I_B on V_{BE}

For output characteristics,
Keep I_B as constant
Study the dependence of I_C on V_{CE}

(Any one)

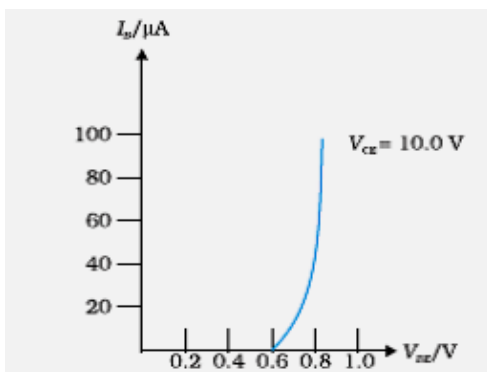

(i) Input characteristics

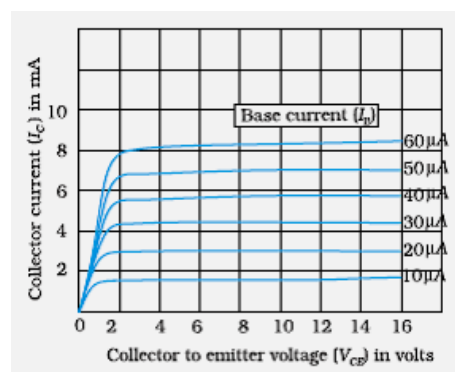

(ii) Output characteristics

(Any one of the above two curves)

1
1
1

3

OR

Drawing circuit diagram	1
Principle	1/2
Working	1/2
Input and output waveform	1/2
Role of capacitor	1/2

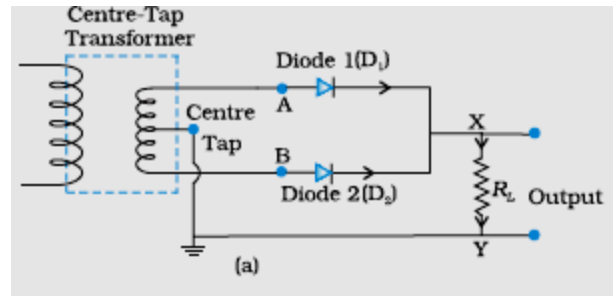

Principle: When the diode is forward biased, it conducts and when it is reverse biased, it does not conduct.

Working: Secondary of the transformer has a center tap. The two diodes conduct during alternate half cycles but the current, in the load, flows in the same direction during both the half cycles.

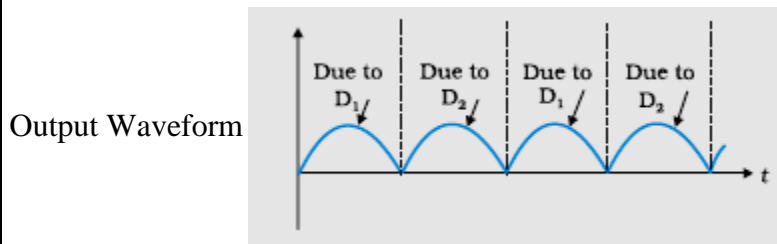
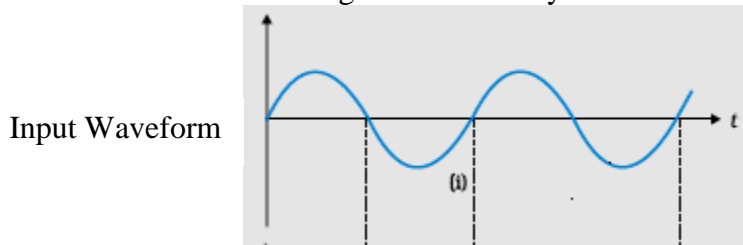

Role of capacitor is to smoothen the output. (also accept any other answer)

1
1/2
1/2
1/2
1/2

3

Set1,Q16
Set2,Q13
Set3,Q14

Diagram	1
Explanation of working principle	1
Obtaining the mathematical expression	1

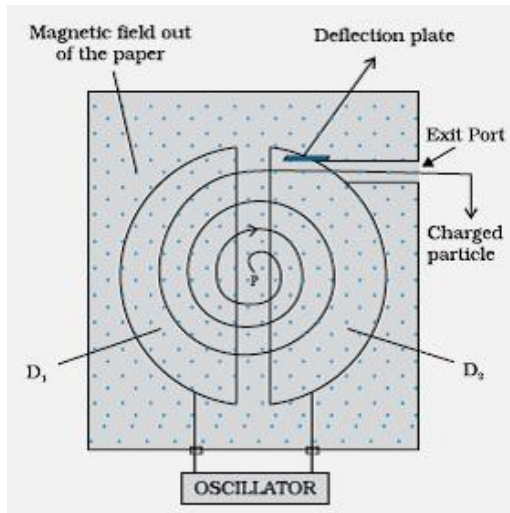

A charged particle can be accelerated to very high energy by subjecting it to an oscillating electric field applied between the dees. When the charged particle is subjected to a uniform magnetic field, it moves in a circular path. Both the fields are perpendicular to each other. The time for one revolution of the charged particle is independent of its speed or radius of its orbit.

$$Bqv = \frac{mv^2}{r}$$

$$v = \frac{Bqr}{m}$$

$$\therefore T = \frac{2\pi r}{v}$$

$$\therefore T = \frac{2\pi m}{Bq}$$

1

1

1/2

1/2

3

Set1,Q17
Set2,Q16
Set3,Q15

Expression for resultant intensity	1
Finding intensity at the given point on the screen	2

Resultant Intensity

$$I = 4I_o \cos^2\left(\frac{\phi}{2}\right)$$

Alternatively : $I_R = I_o + I_o + 2I_o \cos\phi$

When the path difference is λ , phase difference is 2π

$$\therefore I_R = I_o + I_o + 2I_o$$

$$= 4I_o = K$$

If path difference is $\frac{\lambda}{4}$, phase difference is $\frac{\pi}{2}$

$$\therefore I_R = I_o + I_o + 0$$

$$= 2I_o = \frac{K}{2}$$

1

1/2

1/2

1/2

1/2

3

Set1,Q18
Set2,Q17
Set3,Q16

Writing three factors	1 1/2
Explanation to overcome these factors	1 1/2

Three factors that prevent us from sending the signals directly are:

- (i) Size of antenna
- (ii) Power radiated by the antenna

1/2

1/2

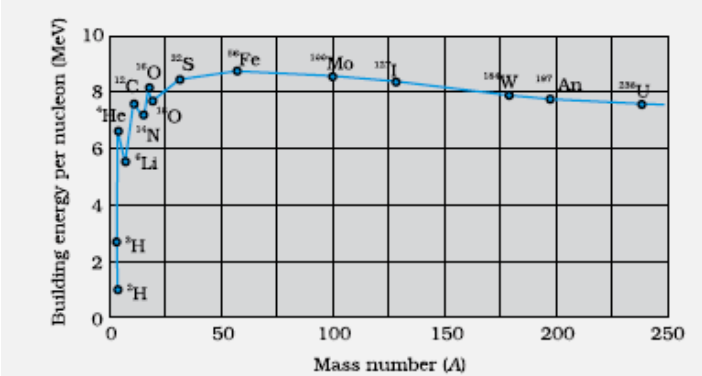
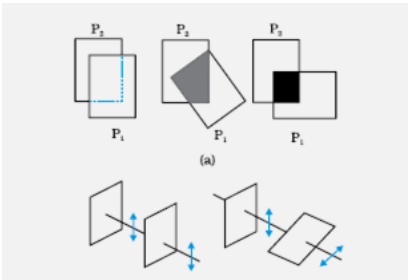
	<p>(iii) Intermixing of signals</p> <p>To overcome these factors</p> <p>(i) Size of antenna should be comparable to wavelength (around $\lambda/4$).</p> <p>(ii) Power depends inversely on λ^2 - Power radiated increases with decrease of wavelength.</p> <p>(iii) Message signal should be used to modulate a high frequency carrier wave so that a band of frequencies can be allotted to each message signal.</p>	<p>1/2</p> <p>1/2</p> <p>1/2</p>	<p>3</p>								
<p>Set1,Q19 Set2,Q18 Set3,Q21</p>	<table border="1" data-bbox="268 528 1257 667"> <tr> <td>(a) Binding Energy/nucleon graph</td> <td>1 1/2</td> </tr> <tr> <td>Property</td> <td>1/2</td> </tr> <tr> <td>(b) Finding Atomic number and Mass number of A</td> <td>1</td> </tr> </table> <p>(a)</p>  <p>Nuclear forces are short ranged / saturated (any one)</p> <p>(b) ${}_{70}A^{180} \xrightarrow{\alpha} {}_{68}A_1^{176} \xrightarrow{\beta^-} {}_{69}A_2^{176} \xrightarrow{\gamma} {}_{69}A_3^{176}$</p> <p>Mass number of A is 180 Atomic number of A is 70</p> <p>Alternatively</p> <p>${}_{72}A^{180} \xrightarrow{\alpha} {}_{70}A_1^{176} \xrightarrow{\beta^+} {}_{69}A_2^{176} \xrightarrow{\gamma} {}_{69}A_3^{176}$</p> <p>Mass number of A is 180 Atomic number of A is 72</p>	(a) Binding Energy/nucleon graph	1 1/2	Property	1/2	(b) Finding Atomic number and Mass number of A	1	<p>1/2</p> <p>1/2</p> <p>1/2</p>	<p>3</p>		
(a) Binding Energy/nucleon graph	1 1/2										
Property	1/2										
(b) Finding Atomic number and Mass number of A	1										
<p>Set1,Q20 Set2,Q19 Set3,Q22</p>	<table border="1" data-bbox="258 1514 1248 1684"> <tr> <td>Diagram</td> <td>1/2</td> </tr> <tr> <td>Explanation</td> <td>1</td> </tr> <tr> <td>Graph</td> <td>1/2</td> </tr> <tr> <td>Understanding graph using Malus' law</td> <td>1</td> </tr> </table> 	Diagram	1/2	Explanation	1	Graph	1/2	Understanding graph using Malus' law	1	<p>1/2</p>	
Diagram	1/2										
Explanation	1										
Graph	1/2										
Understanding graph using Malus' law	1										

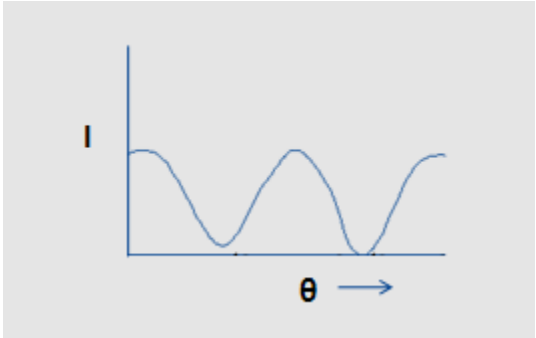
	<p>When light from an ordinary source passes through a polaroid sheet P_1, its intensity is reduced by half. When the second polaroid (identical to the first one) is rotated with respect to the first one, the intensity of the light transmitted by the second polaroid varies from zero to maximum.</p>  <p>According to Malus's law when the angle between the two polaroids is θ, the intensity of the transmitted light by the second polaroid is given by the relation</p> $I = I_0 \cos^2 \theta$ <p>As θ keep on changes, intensity of the transmitted light by the second polaroid changes.</p>	<p>1/2</p> <p>1</p> <p>1</p>	<p>3</p>						
<p>Set1,Q21 Set2,Q14 Set3,Q11</p>	<table border="1" data-bbox="256 936 1246 1077"> <tr> <td>(a) Calculation of current</td> <td>1</td> </tr> <tr> <td>(b) Voltage across resistor and capacitor</td> <td>1/2 + 1/2</td> </tr> <tr> <td>Paradox and its resolution</td> <td>1/2 + 1/2</td> </tr> </table> <p>(a) Current in the circuit</p> $I = \frac{V}{\sqrt{R^2 + \left(\frac{1}{C\omega}\right)^2}}$ $I = \frac{220}{\sqrt{100^2 + \left(\frac{1}{\frac{100}{\pi} \times 10^{-6} \times 2\pi \times 50}\right)^2}}$ $= \frac{2.2}{\sqrt{2}} \text{ A} = 1.55 \text{ A}$ <p>(b) Voltage across the resistor = $100 \times 1.55 \text{ V}$ = 155 volt</p> <p>Voltage across the capacitor = $100 \times 1.55 \text{ V}$ = 155 volt</p> <p>Yes The sum of the two voltages is greater than 220 V but the voltage across the resistor and the capacitor are not in phase.</p>	(a) Calculation of current	1	(b) Voltage across resistor and capacitor	1/2 + 1/2	Paradox and its resolution	1/2 + 1/2	<p>1/2</p> <p>1/2</p> <p>1/2</p> <p>1/2</p> <p>1/2</p> <p>1/2</p>	<p>3</p>
(a) Calculation of current	1								
(b) Voltage across resistor and capacitor	1/2 + 1/2								
Paradox and its resolution	1/2 + 1/2								
<p>Set1,Q22 Set2,Q15 Set3,Q12</p>	<table border="1" data-bbox="256 1854 1246 1995"> <tr> <td>Explanation of drift of electrons</td> <td>1</td> </tr> <tr> <td>Definition</td> <td>1/2</td> </tr> <tr> <td>Showing $\vec{j} = \sigma \vec{E}$</td> <td>1 1/2</td> </tr> </table>	Explanation of drift of electrons	1	Definition	1/2	Showing $\vec{j} = \sigma \vec{E}$	1 1/2		
Explanation of drift of electrons	1								
Definition	1/2								
Showing $\vec{j} = \sigma \vec{E}$	1 1/2								

	<p>When metal conductor is subjected to a certain potential the electron get accelerated due to electric field. Each electron experiences acceleration for an average time, τ, called the relaxation time. It then undergoes a collision and its velocity again becomes random. The average(drift) velocity of all the electrons contributes to the flow of current.</p> <p>The average velocity of electrons, acquired through their acceleration for a time τ is called drift velocity. $v_d = \frac{eE}{m} \tau$</p> <p>Current density</p> $j = \frac{I}{A}$ $= \frac{neAv_d}{A}$ $= ne \left\{ \frac{eE}{m} \tau \right\}$ $= \left(\frac{ne^2\tau}{m} \right) E$ $\therefore \vec{j} = \sigma \vec{E}$	1	
		1/2	
		1/2	
		1/2	
		1/2	
			3

Section D

<p>Set1,Q23 Set2,Q23 Set3,Q23</p>	<table border="1"> <tr> <td>The qualities displayed by Deepika, Ruchika and the teacher</td> <td>2</td> </tr> <tr> <td>Principle of galvanometer</td> <td>1</td> </tr> <tr> <td>Shape of the magnets and why is it so designed</td> <td>1</td> </tr> </table> <p>a) The values displayed by Deepika and Ruchika are their inquisitiveness for practical knowledge. The teacher displayed concern for the students.</p> <p>b) Principle: When a current passes through a coil, placed in a uniform magnetic field, it experiences a torque.</p> <p>c) The pole pieces of the magnet are given a concave shape. This is done to produce a radial magnetic field.</p>	The qualities displayed by Deepika, Ruchika and the teacher	2	Principle of galvanometer	1	Shape of the magnets and why is it so designed	1	1	
The qualities displayed by Deepika, Ruchika and the teacher	2								
Principle of galvanometer	1								
Shape of the magnets and why is it so designed	1								
		1							
		1							
		1/2							
		1/2							
			4						

Section E

<p>Set1,Q24 Set2,Q25 Set3,Q26</p>	<table border="1"> <tr> <td>Flux through the flat faces</td> <td>1 1/2</td> </tr> <tr> <td>Flux through the curved surface</td> <td>1</td> </tr> <tr> <td>Net flux</td> <td>1</td> </tr> <tr> <td>The charge inside the cylinder</td> <td>1 1/2</td> </tr> </table> <p>(i) Flux = $\int \vec{E} \cdot \vec{ds}$ Flux through the flat surface on the:</p> <p>i. right side = $E_0 \cdot \pi r^2$ (outwards)</p> <p>ii. left side = $E_0 \cdot \pi r^2$ (outwards)</p>	Flux through the flat faces	1 1/2	Flux through the curved surface	1	Net flux	1	The charge inside the cylinder	1 1/2	1/2	
Flux through the flat faces	1 1/2										
Flux through the curved surface	1										
Net flux	1										
The charge inside the cylinder	1 1/2										
		1/2									
		1/2									

	<p>(ii) Flux through the curved surface = 0 [As electric field and area vector are perpendicular to each other]</p> <p>Net outward flux = $\pi r^2 E_o + \pi r^2 E_o + 0 = 2\pi r^2 E_o$</p> <p>Charge inside the cylinder = Net flux $\times \epsilon_o$ $= (2 \pi r^2 E_o) \times \epsilon_o$ $= 2 \pi \epsilon_o r^2 E_o$</p> <p style="text-align: center;">OR</p> <table border="1" style="width: 100%; border-collapse: collapse;"> <tr> <td>Electric field outside the plates</td> <td style="text-align: right;">1/2 + 1/2</td> </tr> <tr> <td>Electric field between the plates</td> <td style="text-align: right;">1/2</td> </tr> <tr> <td>Capacitance Expression</td> <td style="text-align: right;">1 1/2</td> </tr> <tr> <td>Effect on electric field on introducing the dielectric</td> <td style="text-align: right;">1</td> </tr> <tr> <td>Effect on Capacitance with dielectric</td> <td style="text-align: right;">1</td> </tr> </table> <p>(a) Calculation of electric field</p> <p>(i) Electric field outside the plates: $\frac{\sigma}{2\epsilon_o} + \frac{(-\sigma)}{2\epsilon_o} = 0$ on both the sides of the capacitor.</p> <p>(ii) Electric fields between the two plates</p> <p style="padding-left: 40px;">due to the left plate = $\frac{\sigma}{2\epsilon_o}$ towards right</p> <p style="padding-left: 40px;">due to the right plate = $\frac{\sigma}{2\epsilon_o}$ towards right</p> <p style="padding-left: 40px;">\therefore Net Electric field = $\frac{\sigma}{\epsilon_o}$ (towards right)</p> <p>Capacitance, $C = \frac{Q}{V}$</p> <p style="padding-left: 40px;">$= \frac{Q}{Ed} = \frac{\sigma A}{(\frac{\sigma d}{\epsilon_o})}$</p> <p style="padding-left: 40px;">$= \epsilon_o A/d$</p> <p>(b) (i) When a dielectric slab is introduced, the Electric field decreases to $\frac{E}{K} = \frac{\sigma}{K\epsilon_o}$ where K is the dielectric constant. This is because of the (oppositely directed) field due to the polarized dielectric.</p> <p>(ii) Capacitance with dielectric increases by a factor K because the electric field (and hence p.d.) decreases by a factor K.</p>	Electric field outside the plates	1/2 + 1/2	Electric field between the plates	1/2	Capacitance Expression	1 1/2	Effect on electric field on introducing the dielectric	1	Effect on Capacitance with dielectric	1	<p>1/2 1/2</p> <p>1</p> <p>1/2 1/2 1/2</p> <p>5</p> <p>1/2 + 1/2</p> <p>1/2</p> <p>1/2</p> <p>1/2</p> <p>1</p> <p>1</p>	5
Electric field outside the plates	1/2 + 1/2												
Electric field between the plates	1/2												
Capacitance Expression	1 1/2												
Effect on electric field on introducing the dielectric	1												
Effect on Capacitance with dielectric	1												
<p>Set1,Q25 Set2,Q26 Set3,Q24</p>	<table border="1" style="width: 100%; border-collapse: collapse;"> <tr> <td>(a) Main considerations</td> <td style="text-align: right;">1 + 1</td> </tr> <tr> <td>(b) Ray diagram</td> <td style="text-align: right;">1</td> </tr> <tr> <td style="padding-left: 20px;">Magnifying Power</td> <td style="text-align: right;">1</td> </tr> <tr> <td>(c) Advantages (any two)</td> <td style="text-align: right;">1/2 + 1/2</td> </tr> </table>	(a) Main considerations	1 + 1	(b) Ray diagram	1	Magnifying Power	1	(c) Advantages (any two)	1/2 + 1/2				
(a) Main considerations	1 + 1												
(b) Ray diagram	1												
Magnifying Power	1												
(c) Advantages (any two)	1/2 + 1/2												

a) Better Light gathering power and higher resolving power

b)

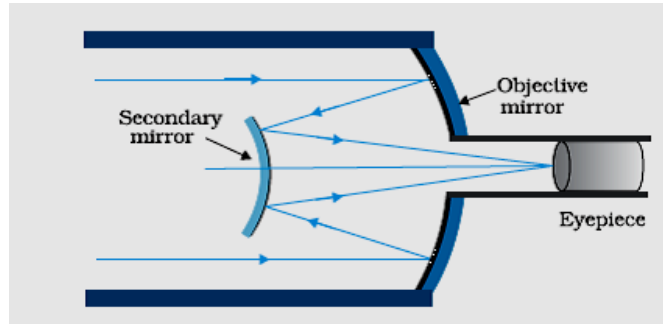

Magnifying power of the telescope is the ratio of the angle subtended at the eye by the final image to the angle subtended by the object at the lens or the eye.

[Also accept if the student just writes $m = \frac{f_o}{f_e}$]

- 1) Larger objective size
 - 2) No spherical aberration,
 - 3) No chromatic aberration,
 - 4) More light gathering power
 - 5) Mounting and polishing is easier
 - 6) More economical
- [any two points]

OR

(a) Diagram	2
(b) Minimum separation	1½
Relation with resolving power	½
Factors by which resolving power can be increased	1

(a)

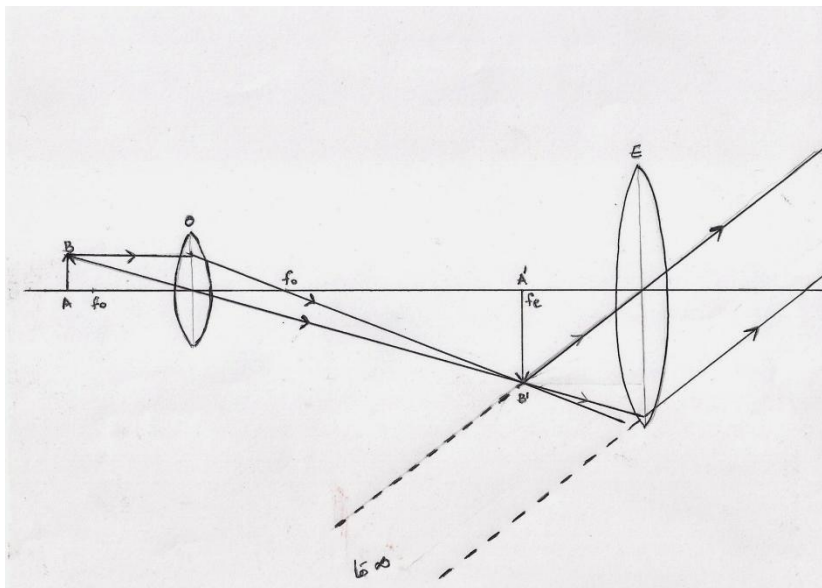

[Also accept if the student draws the following diagram]

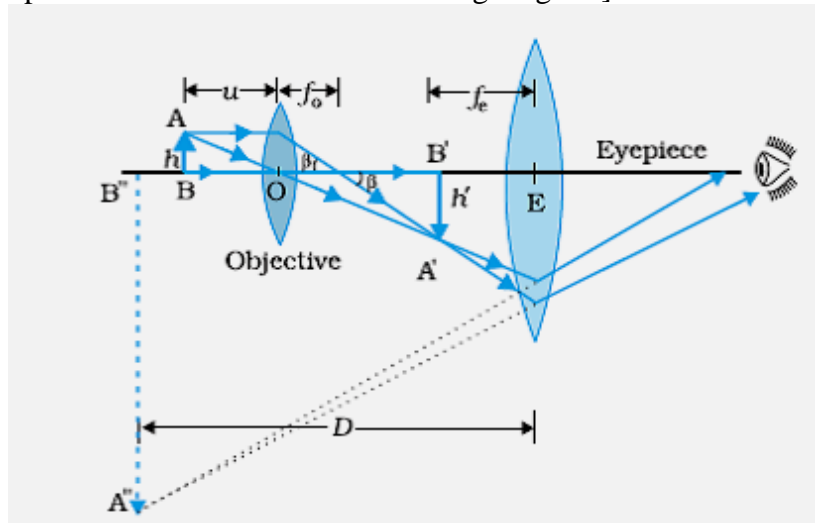

(b) $S = \text{Size of image of a point object in the image plane} = v \left(\frac{1.22 \lambda}{d} \right)$
 Minimum separation between two distinctly seen points in the object plane = $\frac{S}{\text{Magnifying Power}}$

$$= \frac{S}{\left(\frac{v}{f}\right)} = \frac{1.22 f \lambda}{D}$$

[Also give this mark if the student writes

(i) Minimum separation = $\frac{1.22 f \lambda}{D}$

Or (ii) Minimum separation equals the separation at which their images are just resolved

Or (iii) Minimum separation corresponds to 'limit of resolution'.]

$$\text{Resolving power} = \frac{1}{d} = \frac{2\mu \sin \theta}{1.22 \lambda}$$

[Also accept: Resolving power $\propto \frac{1}{(\text{minimum separation})}$]

Resolving power can be increased by

- (i) increasing the aperture of the objective
- (ii) using a medium with higher refractive index
- (iii) by decreasing the wavelength of the light used for illuminating the object

[Any two]

Set1,Q26
Set2,Q24
Set3,Q25

(a) Meaning of mutual inductance	1
(b) Expression for the mutual inductance of the arrangement	2
(c) Expression for the emf induced	2

(a) Consider two long co-axial solenoids. When a varying current flows through one coil, an induced emf is set up in the second coil due to the variation in the magnetic field associated with the second coil. This phenomena is known as mutual induction

(b) Flux (ϕ_1) associated with S_1 when I_2 current flows through S_2

$$N_1\phi_1 = M_{12}I_2 \text{ -----(1)}$$

The magnetic field due to the current I_2 in S_2 is $\mu_0 n_2 I_2$

$$\begin{aligned} \therefore N_1\phi_1 &= (n_1 l)(\pi r_1^2)(\mu_0 n_2 I_2) \\ &= \mu_0 n_1 n_2 \pi r_1^2 l I_2 \text{ -----(2)} \end{aligned}$$

From (1) and (2), we get

$$M_{12} = \mu_0 n_1 n_2 \pi r_1^2 l$$

(c) Induced emf in coil C_1 due to the change in current through C_2

We have $N_1\phi_1 = M I_2$

For varying currents,

$$N_1 \left(\frac{d\phi_1}{dt} \right) = M \left(\frac{dI_2}{dt} \right)$$

$$\therefore -\varepsilon_1 = M \left(\frac{dI_2}{dt} \right)$$

$$\text{or } \varepsilon_1 = -M \left(\frac{dI_2}{dt} \right)$$

OR

(a) Statement of Ampere's circuital law	1
Derivation of magnetic field B	2
(b) Magnetic field inside the thick wire	1
outside the wire	1/2
Graph	1/2

(a) Ampere's Circuital law states that the line integral of the magnetic field, over a closed loop is equal to μ_0 times the total current passing through the surface enclosed by the loop.

$$\text{Alternatively, } \oint \vec{B} \cdot d\vec{l} = \mu_0 I$$

Let an infinite straight wire carry a current I . We consider a circle of radius r , centered on the wire, and having its plane perpendicular to the wire.

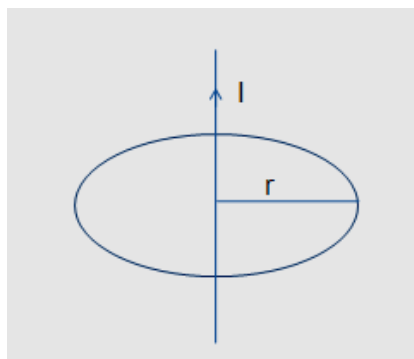

By right hand rule, the magnetic field is tangential at every point of this circular loop.

∴ By Ampere's circuital law,

$$\oint \vec{B} \cdot d\vec{l} = B \cdot 2\pi r = \mu_0 I$$

$$\therefore B = \frac{\mu_0 I}{2\pi r}$$

(b) For $r < a$, we have

$$B \cdot 2\pi r = \mu_0 I_{\text{enclosed}}$$

$$= \mu_0 \left(\frac{\pi r^2}{\pi a^2} \right) I$$

$$= \frac{\mu_0 r^2}{a^2} I$$

$$\therefore B = \frac{\mu_0}{2\pi} \frac{I}{a^2} r$$

For $r > a$

$$B \cdot 2\pi r = \mu_0 I$$

$$\text{or } B = \frac{\mu_0 I}{2\pi r}$$

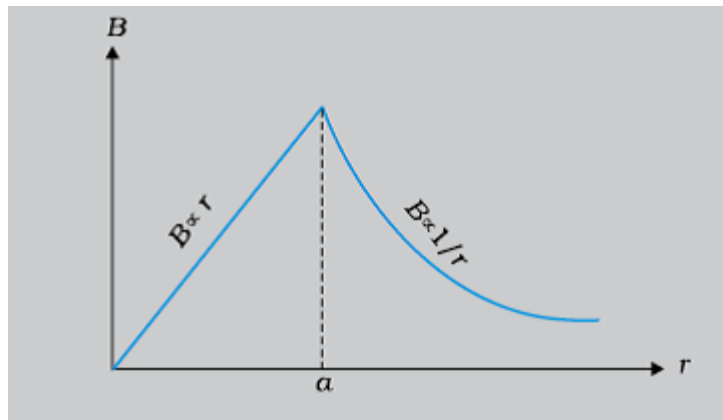

1

$\frac{1}{2}$

$\frac{1}{2}$

$\frac{1}{2}$

$\frac{1}{2}$

$\frac{1}{2}$